

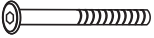

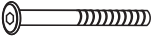





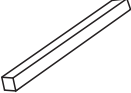

ASSEMBLY INSTRUCTION

Item	Size	Parts	Qty
A	M8x90mm		8
B	M6x75mm		8
C	M6x55mm		10
D	M8		8
E	M5		2
F	M4		1
G	52x5x3cm		2
H	50x2x3cm		1
I	60x5x3cm		2
J	155x4x4cm		2
K	166x5x4cm		1
L	128x6x3cm		2

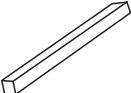

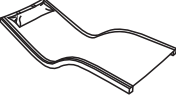
Step 1

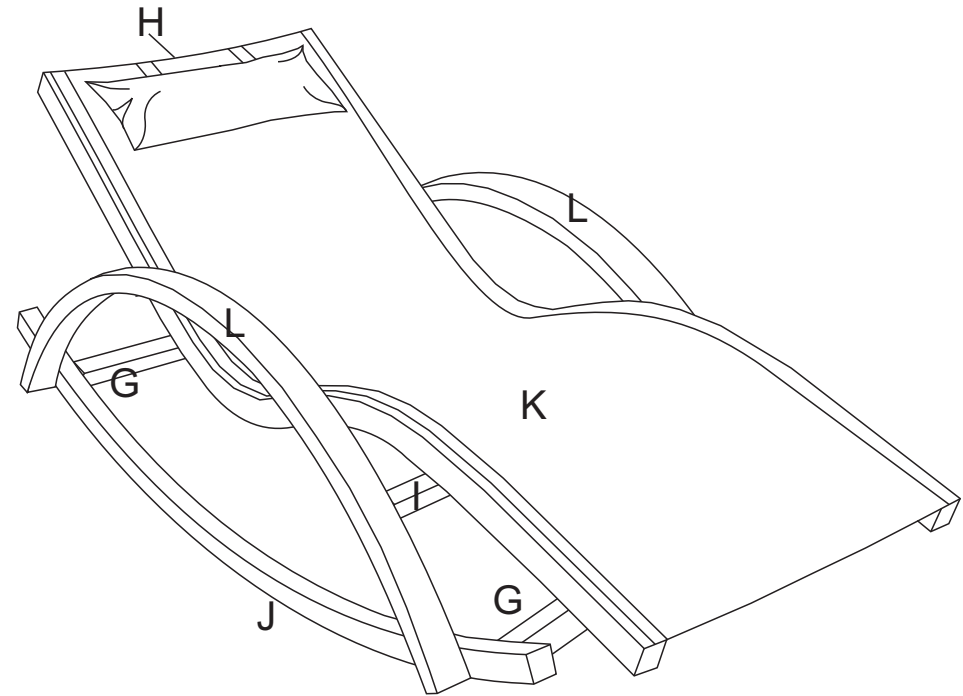
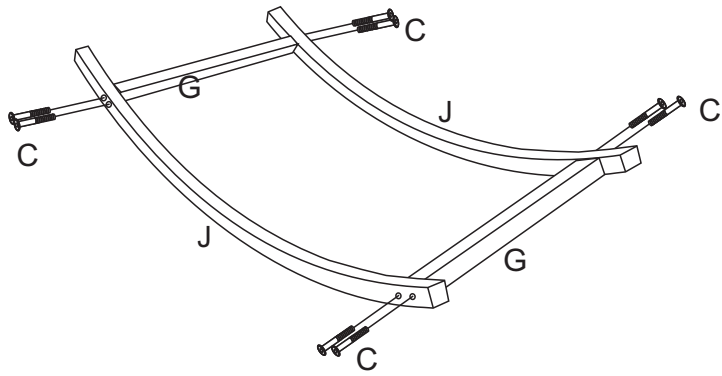

Step 2

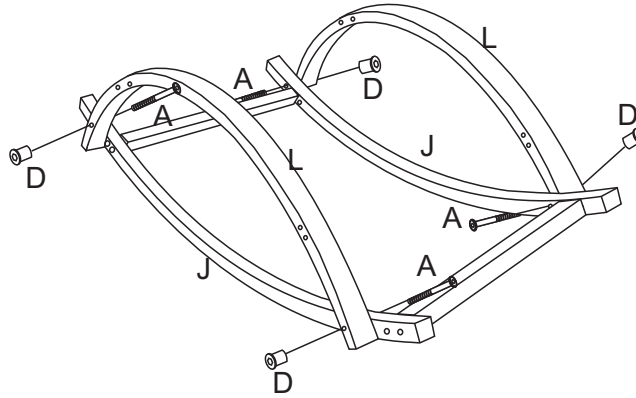

Step 3

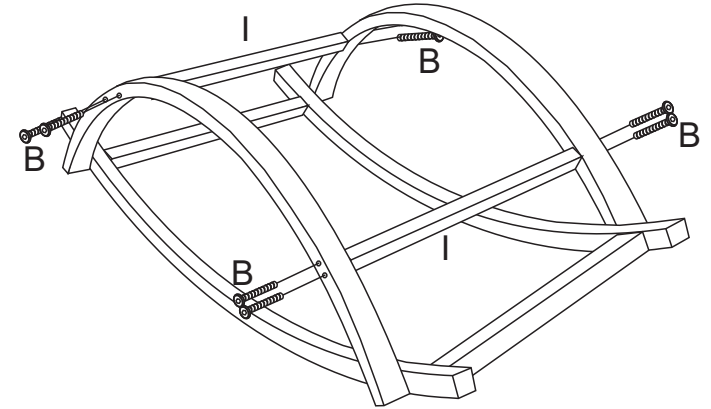

Step 4

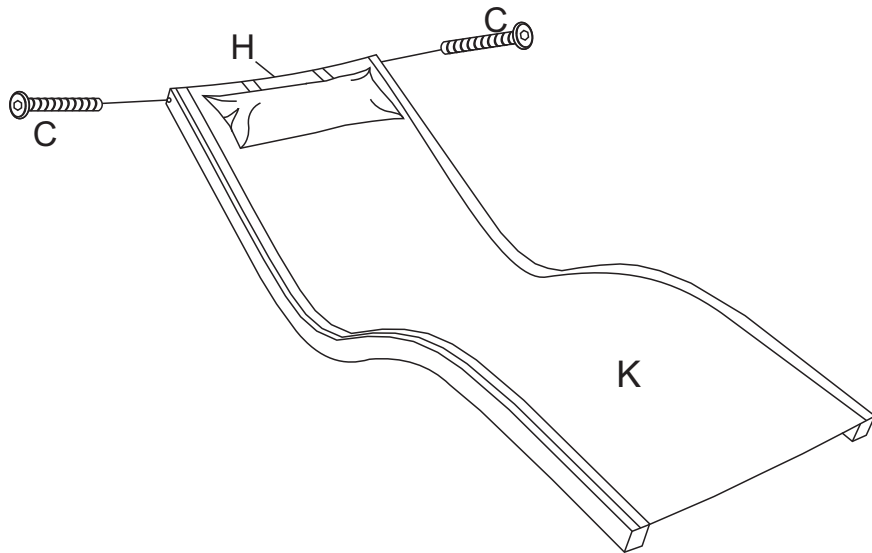

Step 5

